



## Loncin Horizontal GASOLINE Series

### Professional complete power product

Loncin is the only manufacturer that is able to provide full range of engines with horizontal shaft and vertical shaft in China, of which the vertical shaft power products cover 87-678cc. It provides global customers with comprehensive general power solutions and serves as a supplier of professional low-carbon complete power product and service.

### After-sale quality assurance

the products are easy to be started, powerful, durable and reliable, meeting environmental standards and provided with comprehensive after-sales service.

### Tamping machine series

it is a model that is developed aiming at the special requirements for engineering machinery and specific workplaces. It can be widely used for plate tamping, road cutting machine, impact tamper and other engineering machinery.

### First choice of General Purpose Engine

Loncin has provided world-renowned brands-GGP, E-Mark, Toro and Rover with millions of excellent power products continuously. They are widely used for terminal machinery of garden, engineering, agriculture, animal husbandry, fishery and other industries, such as: generator, water pump, mini-tiller, cleaning machine, road cutting machine, tamping machine, chipping machine, etc.

### Double-cylinder series

the balanced design of V-type double cylinder and dynamic crankshaft is adopted so that the engine is more compact with effectively reduced vibration and stable operation. The service life of the engine is extended. High-flow cooling fan, oil filter and oil cooler effectively lowers the engine temperature, enhances engine performance and extends the service life.

### L series

brand new design, with new-style, novel and compact appearance. Camshaft with new patented technology is adopted for strong power. It is suitable for the strength design of large load.

### Snowplow series

it is featured with strong power performance, good economic performance and reliable operation, and can meet the operation requirements of harsh low-temperature environment, stringent environment-friendly regulations and safety regulations.

G200F(D) ▼

Features    Technical Details    Curve graph    P.T.O Shaft Options

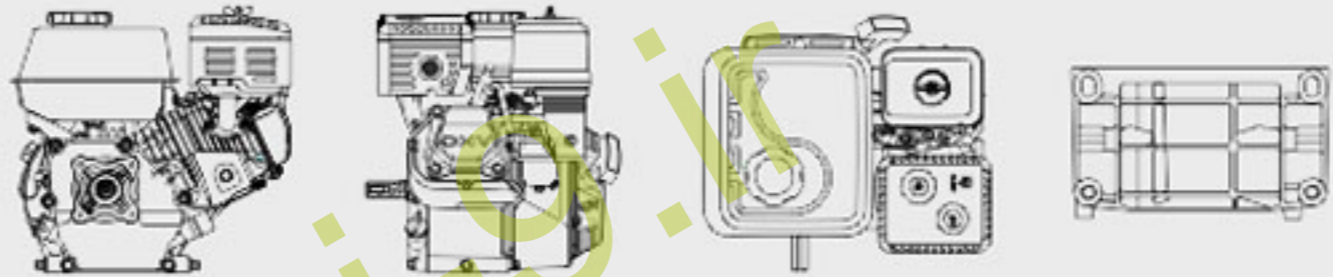

- Overhead valve (OHV) design, lower operation temperature, powerful drive and reliability and durability, and it saves more oil.
- Cast iron casing does not only effectively improve lubrication, but also makes engine more wear-resistant and prolongs engine life.
- Automatic alarm and stop at low oil level, which prevents the engine to work at low oil level and gives more protection to engine.
- Metal cam and forged crankshaft makes engine more reliable and durable.
- Meet with EPA III and CARB Standard.



G200F(D)



Features	Technical Details	Curve graph	P.T.O Shaft Options
Engine type	Single cylinder,4stroke, forced cooling ,OHV		
Displacement	196cc		
Bore×Stroke	68mm×54mm		
Net power	4.1kW/3600rpm		
Net torque	12.4N.m/2500rpm		
Idle speed	1400±150r/min		
Compression ratio	8.5 : 1		
PTO shaft rotation	Anti-clockwise(from PTO side)		
Noise	≤70B(A)		
Ignition system	Transistorized magneto ignition		
Starting system	Recoil start/Electic-start		
Carburetor	Butterfly		
Lubrication system	Splash		
Governor system	Centrifugal mass type		
Air cleaner	Semi-dry,dual element,Oil bath		
Oil capacity	0.6L		
Fuel tank capcity	3.6L		
Net weight	16kg/19kg		
Dimension	376×312×335		

G200F(D)

Features

Technical Details

Curve graph

P.T.O Shaft Options

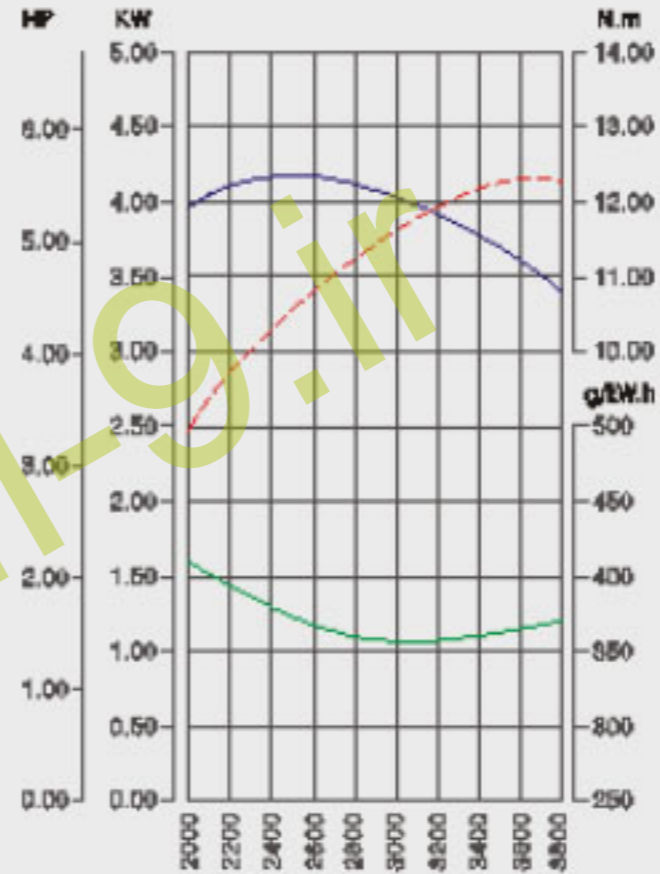

--- 净功率 Net power  
— 净扭矩 Net torque  
— 燃油消耗率 Fuel consumption

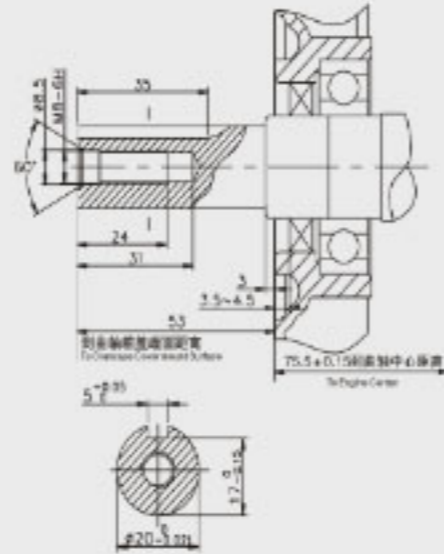

Type A

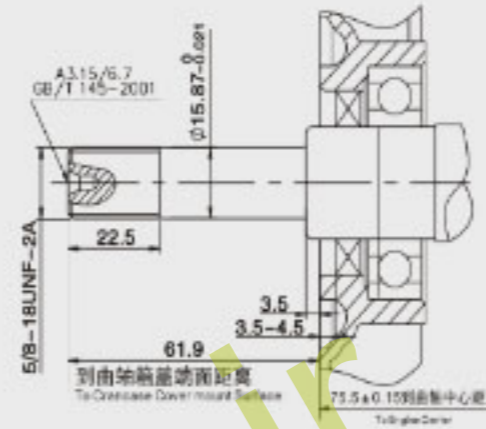

Type A9

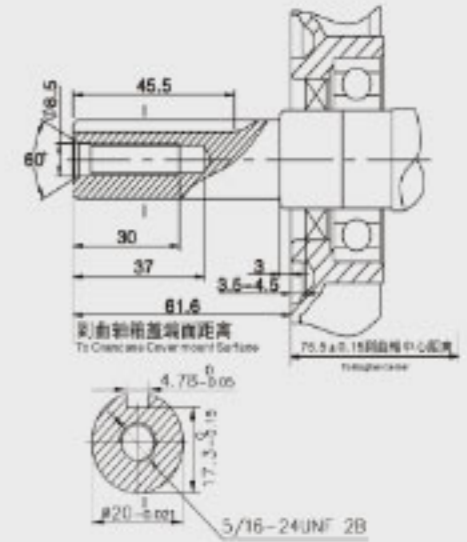

Type A22

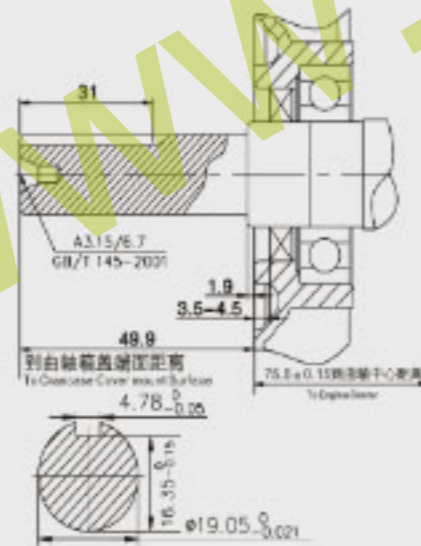

Type A33

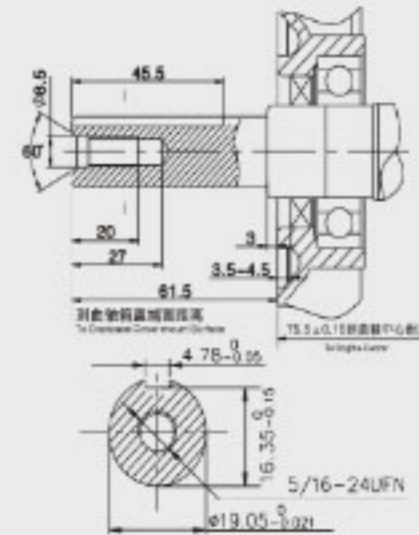

Type A44轴

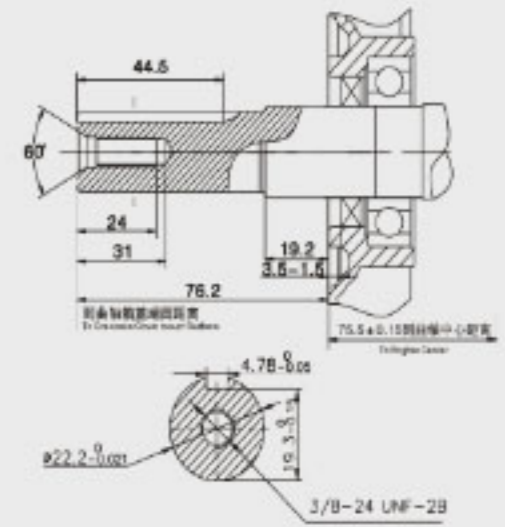

Type A45

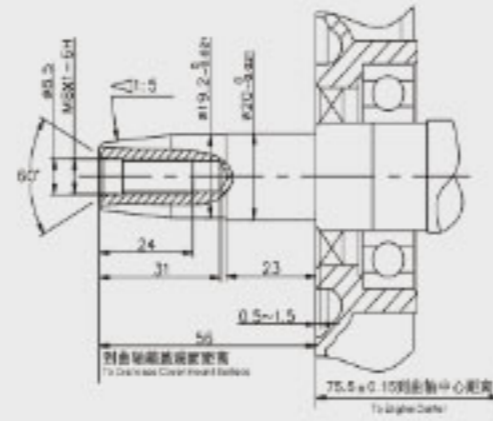

Type C

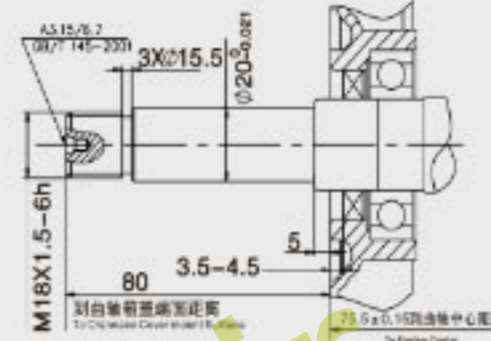

Type D

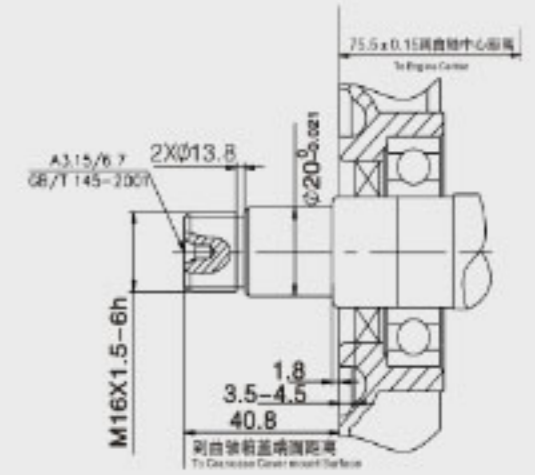

Type E

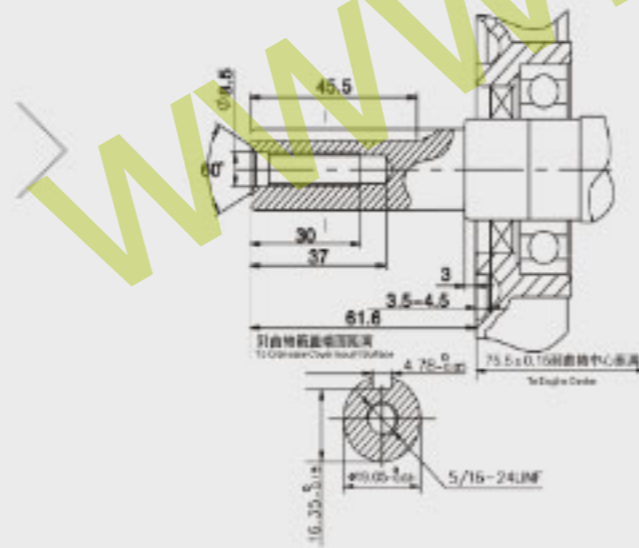

Type R

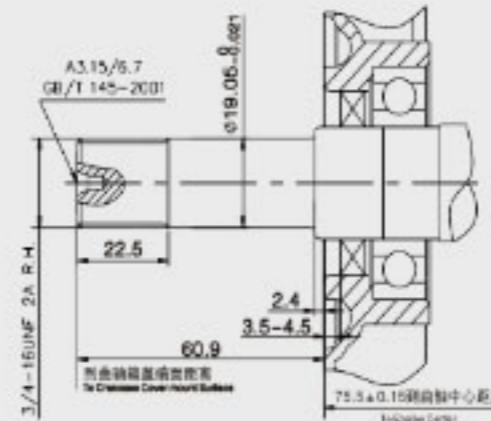

Type S

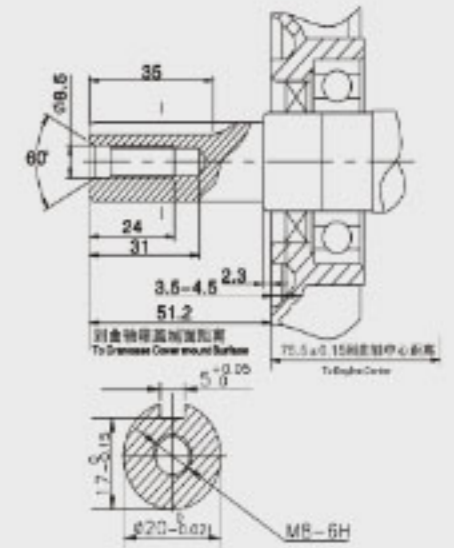

Type U

