



Application

- Can be used to transfer clean water or other liquids similar to water in physical and chemical properties
- Suitable for industrial use and urban water supply, pressure boosting for high buildings and fire fighting, garden irrigation, long-distance water transfer, heating ventilation and air controlling, circulation and pressure boosting for cold and hot water, and supporting equipment etc.

Pump

- Cast iron pump body and support under special anti-rust treatment
- AISI 304 shaft
- Max. liquid temperature: +60°C
- Max. suction: +8 m

Motor

- C&U bearing
- Motor with copper winding
- Built-in thermal protector for single phase motor
- Insulation class: F
- Protection class: IPX4
- Max. ambient temperature: +40°C
- IE 2 motor (Three phase, power ≥ 0.75kW)

Identification Codes

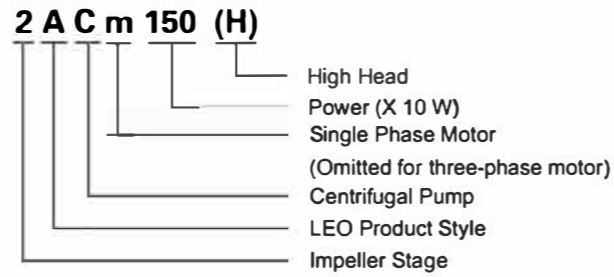

Technical Data

MODEL	POWER	Q (m³/h)	H (m)																
			0	1.2	1.5	2.4	3	3.8	4.2	4.8	5.4	6	6.6	7.2	8.4	9.6	10.8	12	15
2ACm75	0.75	1.0	45	42.5	40	37	33.5	28.5	23	15	-	-	-	-	-	-	-	-	
2ACm110	1.1	1.5	47	46	45	44	43	41.5	40	38	35.5	33	30.5	28	22	-	-	-	
2ACm150	1.5	2	57.5	55.5	54.5	53.5	52	50.5	49	47	44.5	41.5	38.5	35	28	20	-	-	
2ACm150H	1.5	2	63.5	60.5	58.5	56.5	54	51.5	48.5	45	41	37.5	33.5	29	-	-	-	-	
2AC220	2.2	3	65	63	62	61	59.5	58	56	54	51.5	49	46	43	36	28.5	20.5	-	
2ACm300H	3	4	65	-	-	62	61	60	59	58	58.5	55	53.5	52.5	48.5	44.5	40	35	
2AC300H	3	4	70	-	-	67	66	65	64	63	62	61	59.5	59	55.5	52	49	45	
2AC400H	4	5.5	82	-	-	79.5	76.5	77.5	76.5	75.5	74.5	73.5	72	71	67.5	64.5	61	57	

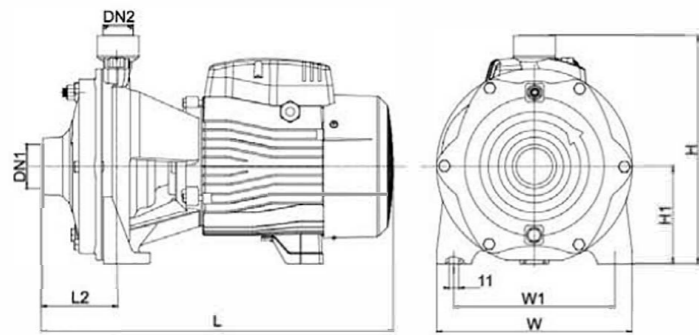

Dimension

Model	DN1	DN2	L (mm)	L ₁ (mm)	H (mm)	H ₁ (mm)	W (mm)	W ₁ (mm)
2ACm75	1 1/4"	1"	336	72	231	100	181	145
2ACm110	1"		379	71	225	93	200	162
2ACm150	1 1/2"	1"	400	80	262	112	225	165
2ACm150H								
2AC220	1 1/4"	1"	480	63	311	132	281	234
2ACm300H								
2AC300H								
2AC400H								

Hydraulic Performance Curves

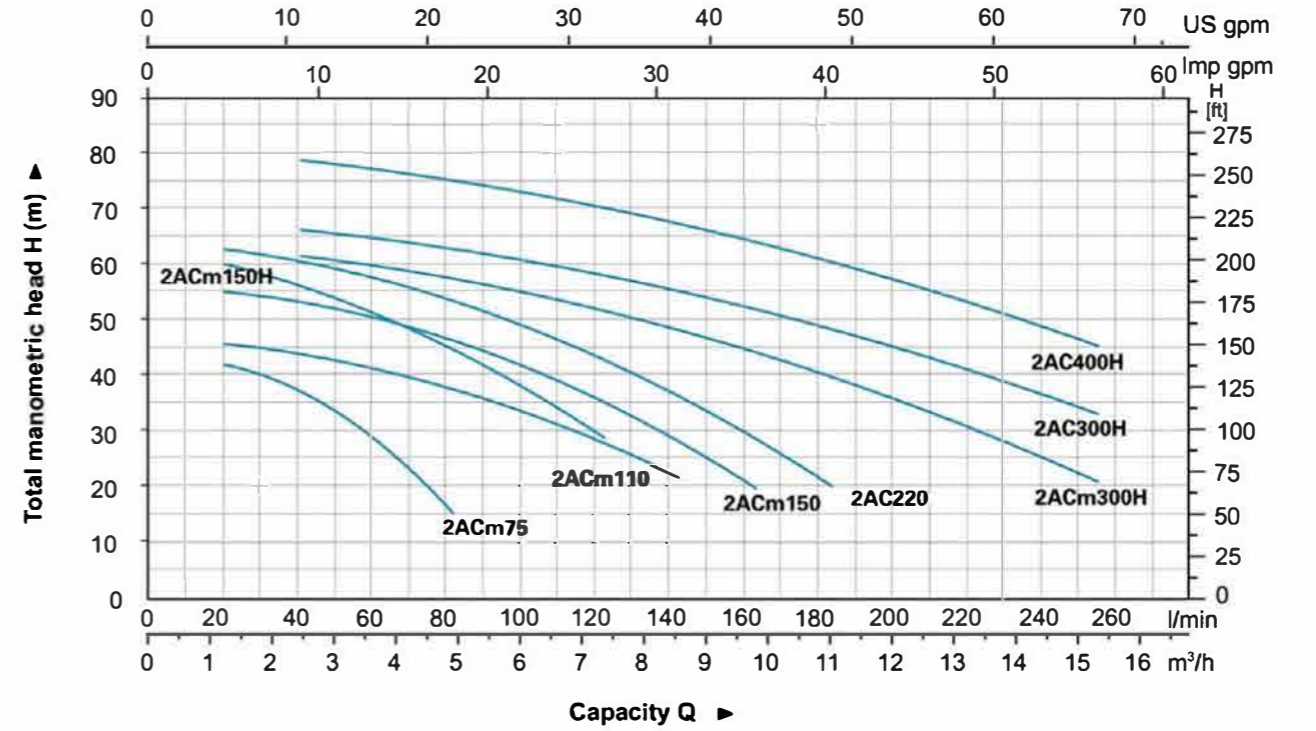

Materials Table

No.	Part	Material
1	Drain plug	HPb59-1
2	Pump body	HT200
3	Gasket	NBR
4	Impeller	AISI 304/Brass HT200
5	Bracket cover	HT200
6	Mechanical seal	Carbon/Ceramic
7	Support	HT200
8	Oil seal	
9	Bearing	
10	Rotor	
11	Stator	
12	Rear cover	ZL102
13	Fan	PP
14	Fan cover	PP
15	Terminal board	PC
16	Capacitor	
17	Terminal box	ABS

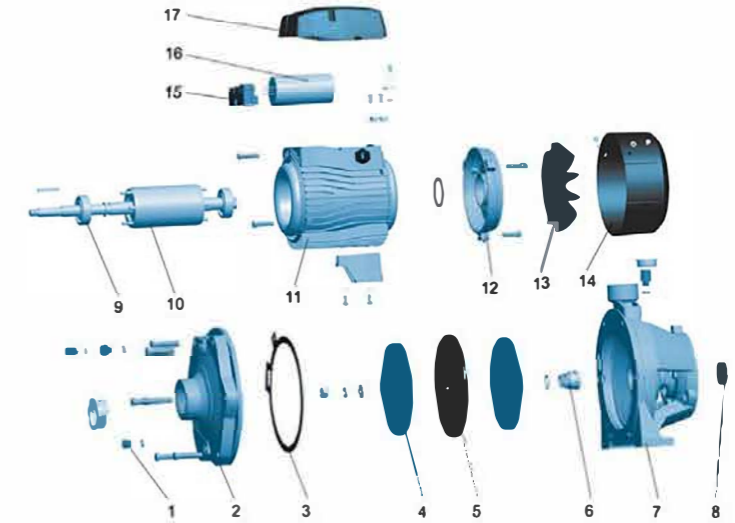

Package Information

Model	GW (Kgs)	L (mm)	W (mm)	H (mm)	Quantity (PCS/20 TEU)
2ACm75	16.8	385	215	270	1190
2ACm110	21	430	235	275	833
2ACm150	27.5	445	255	300	636
2ACm150H	27.8	440	254	299	636
2AC220	27.5	445	255	300	629
2ACm300H	51.9	542	330	346	337
2AC300H	51.5	542	330	346	340
2AC400H	52.4	542	330	346	346

