



Application

- Can be used to transfer clean water or other liquids similar to water in physical and chemical properties
- Suitable for lifting water from the well, sprinkling irrigation in garden, pressure boosting of running water, and supporting equipment etc.

Pump

- Cast iron pump body and support under special anti-rust treatment
- Stainless steel impeller
- AISI 304 shaft
- Max. liquid temperature: +60°C
- Max. suction: +9 m

Motor

- C&U bearing
- Motor with copper winding
- Built-in thermal protector for single phase motor
- Insulation class: F
- Protection class: IPX4
- Max. ambient temperature: +40°C

Identification Codes

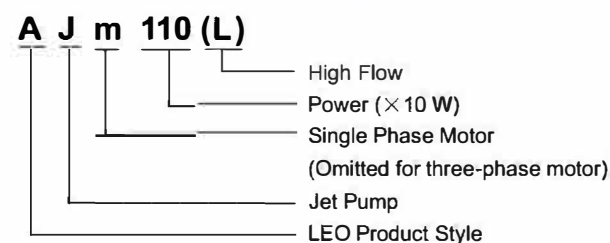

Technical Data

MODEL	POWER		Q (m³/h)																
	kW	HP	0	0.6	0.9	1.2	1.5	1.8	2.1	2.4	2.7	3.0	3.6	4.2	4.8	6.0	7.2	8.4	9.6
AJm110H	1.1	1.5	60	55	55	49	49	46	44	40	39.5	38	36	30	-	-	-	-	-
AJm150H	1.5	2.2	72	66	61	59	54	52	49.5	49	45	42	42	33	-	-	-	-	-
AJ(m)220H	2.2	3	85	78	78	72	73	70	67	61	61	59	53	42	-	-	-	-	-
AJm110	1.1	1.5	55	50	48	47	45	44	42.5	40	39	38	35	31.5	31	23	-	-	-
AJm150	1.5	2.2	60	55	56	53	52	51	49	45	46	45	39	38	33	-	-	-	-
AJ220	2.2	3	68	64	65.5	61	63	61.5	60	55	57	56	51	51	46	41	35	-	-
AJm110L	1.1	1.5	47	45	45	43	42	41	40	38	37.5	36.5	34	31	30	22	21	17	-
AJm150L	1.5	2.2	54	52	46	49	44	43	42	45	40	39	38	35	32	29	24	24	-
AJ220L	2.2	3	55	53	49.5	52	48	47.5	46.5	49	45	44	46	41	43	40	34	26	30

Dimension

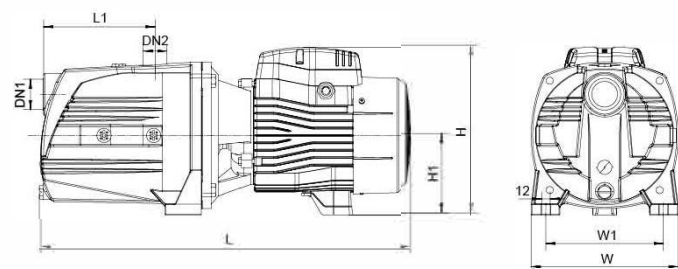

Model	DN1	DN2	L (mm)	W (mm)	H (mm)	L ₁ (mm)	W ₁ (mm)	H ₁ (mm)
AJm110	1 1/4"	1"	512	206	236	153	178	112
AJm110H			512	206	236	153	178	112
AJm110L			512	206	236	153	178	112
AJm150			512	206	236	153	178	112
AJm150H			512	206	236	153	178	112
AJm150L			512	206	236	153	178	112
AJ220	1 1/2"	1 1/2"	512	206	236	153	178	112
AJ(m)220H			512	206	236	153	178	112
AJ220L			512	206	236	153	178	112

Hydraulic Performance Curves

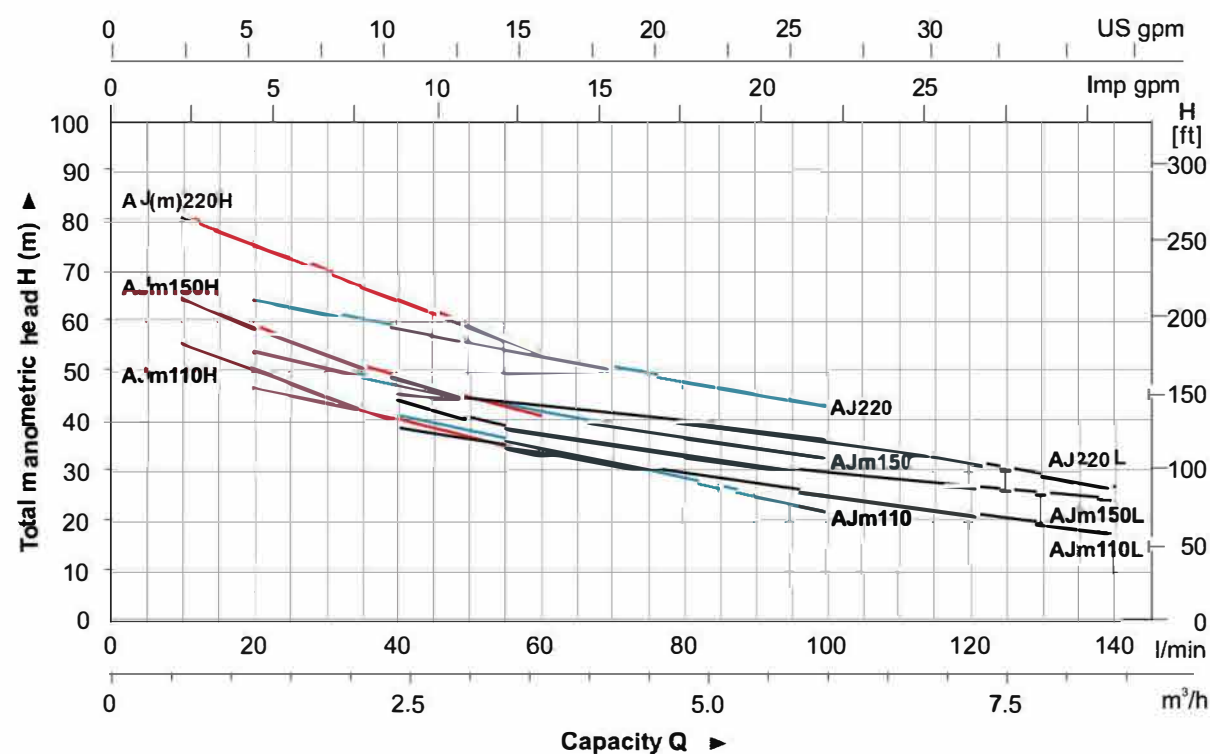

Materials Table

No.	Part	Material
1	Pump body	HT200
2	Nozzle	PPO
3	O-ring	NBR
4	Venturi tube	PPO
5	Diffuser	PPO
6	Mechanical seal	Carbon/Ceramic
7	Impeller	AISI 304
8	Support cover	HT200
9	Support	ZL102
10	Bearing	
11	Rotor	
12	Stator	
13	Terminal board	PC
14	Terminal box	ABS
15	Capacitor	
16	Rear cover	ZL102
17	Fan	PP
18	Fan cover	PP

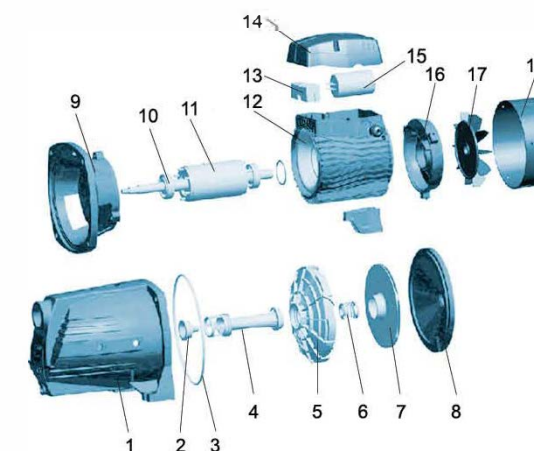

Package Information

Model	GW (Kgs)	L (mm)	W (mm)	H (mm)	Quantity (PCS/20 TEU)
AJm110	24.5	572	225	259	816
AJm110H	24.5	572	225	259	816
AJm110L	24.5	572	225	259	816
AJm150	25.4	572	225	259	816
AJm150H	25.4	572	225	259	816
AJm150L	25.4	572	225	259	816
AJ220	26.0	572	225	259	816
AJ(m)220H	26.0	572	225	259	816
AJ220L	26.0	572	225	259	816

