

APPLICAZIONI

Elettropompe sommerse portatili a funzionamento automatico. Impiegate per prosciugamento acque di infiltrazione; svuotamento di locali allagati o vasche; drenaggio acque di scarico pulite o leggermente sporche; irrigazioni di orti e giardini.

APPLICATION

Hand-carry submersible automatic water pumps. Able to drain infiltrating water, cellars or reservoirs, clean or slightly dirty water and for garden irrigation.

TSN 300/S



TS 400-800/S



LIMITI D'IMPIEGO

- Temperatura liquido fino a 35°C (per un uso domestico secondo EN 60335-2-41)
- Temperatura max. liquido: 35°C (per altri impiegi)
- Massima profondità d'immersione 5 mt.
- Passaggio solidi

-TSN 300	Ø 3mm
-TS 400	Ø 8mm
-TS 800	Ø 10mm
- Livello min. d'aspirazione

-TSN 300	15mm
-TS 400	20mm
-TS 800	20mm

MOTORE

- Protezione amperometrica a riarmo automatico incorporata
- Condensatore permanente inserito
- Isolamento Classe F
- Protezione IP 68

MATERIALI

- | | |
|---------------------------|-----------------------|
| - Maniglia | Polipropilene |
| - Corpo pompa | Polipropilene |
| - Girante | Noryl |
| - Cassa motore | Acciaio Inox AISI 304 |
| - Albero motore | Acciaio Inox AISI 304 |
| - Triplo anello di tenuta | |

OPERATING CONDITIONS

- Liquid temperature up to 35°C (for home use according to EN 60335-2-41)
- Temperature max. liquid: 35°C (for other uses)
- Maximum immersion depth 5 mt.
- Grain size inlet

-TSN 300	Ø 3mm
-TS 400	Ø 8mm
-TS 800	Ø 10mm
- Min. suction level

-TSN 300	15mm
-TS 400	20mm
-TS 800	20mm

MOTOR

- Built-in overload motor protector with automatic reset
- Permanent split capacitor
- Insulation Class F
- Protection IP 68

MATERIALS

- | | |
|--------------------|--------------------------|
| - Handle | Moplen |
| - Pump body | Moplen |
| - Impeller | Noryl |
| - Motor casing | Stainless Steel AISI 304 |
| - Shaft with rotor | Stainless Steel AISI 304 |
| - Triple oil seal | |

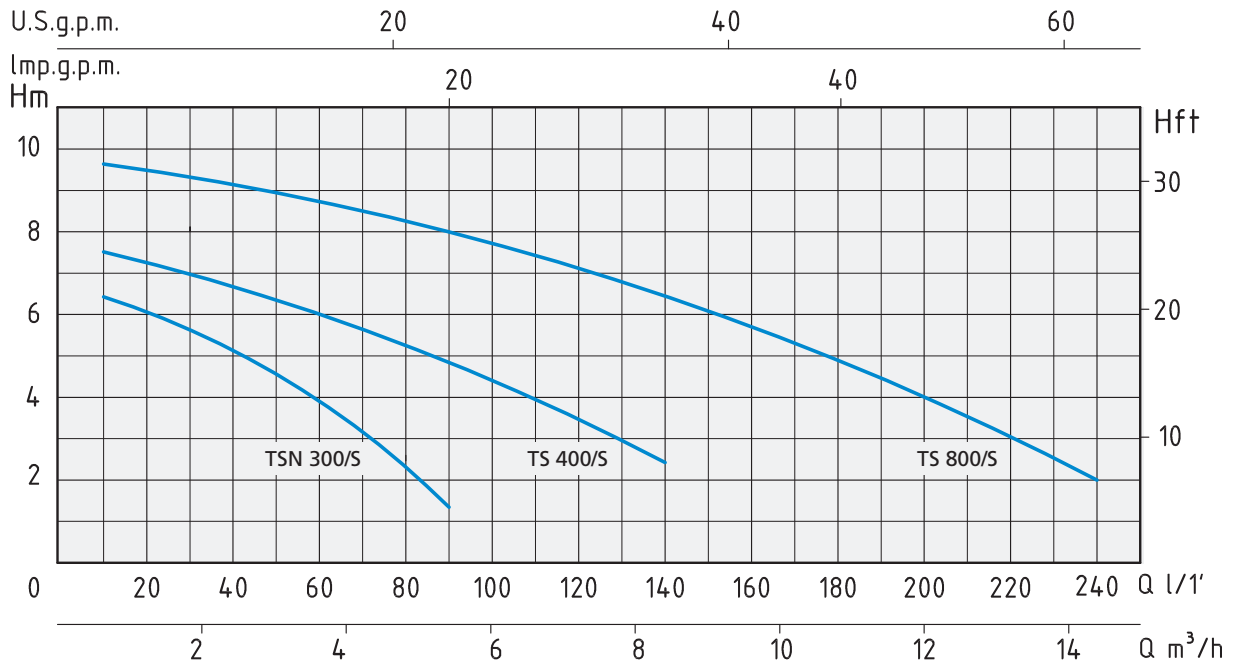

TIPO TYPE	POTENZA ASSORBITA INPUT POWER	AMPERE	Condensatore Capacitor	Q = PORTATA - CAPACITY											
				m³/h	0,6	1,2	1,8	2,4	3,6	5,4	8,4	10,8	14,4		
Monofase Single-phase	P1	Monofase Single-phase	µf	lt/1'	10	20	30	40	60	90	140	180	240		
230V-50Hz	Watt	1 x 230V		Prevalenza manometrica totale in m.C.A. - Total head in meters w.c.											
TSN 300/S	300 W	1,6	5	H (m)	6,3	5,5	5,1	4,3	3,5	1,3					
TS 400/S	400 W	2	8		7,5	6,8	6,5	6	5,5	4,5	2,3				
TS 800/S	800 W	3,8	20		9,7	9,5	9,2	9	8,7	8	6,6	5	2		

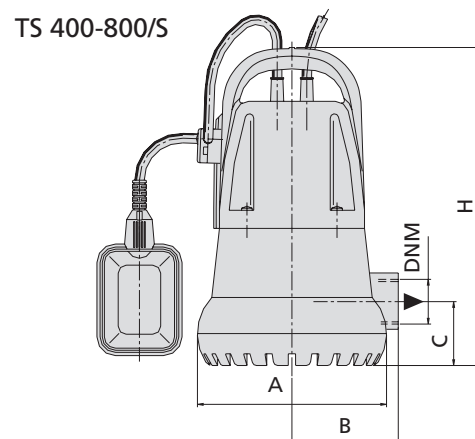
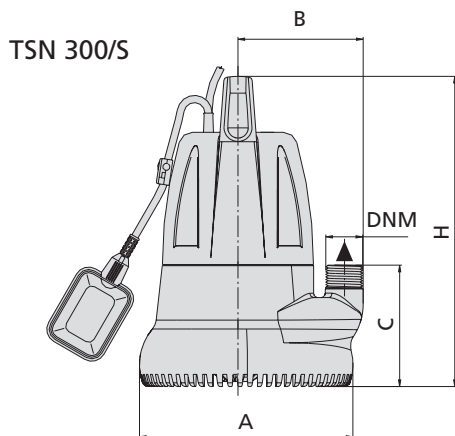

TIPO TYPE	DIMENSIONI mm - DIMENSIONS mm						DIMENSIONI DIMENSIONS mm			PESO WEIGHT Kg
	A	B	C	H	DNM	CAVO CABLE	P	L	H	
Monofase Single-phase										
TSN 300/S	180	113	112	280	1"	10 mt H05RNF	222	218	316	4,8
TS 400/S	180	94	60	300	1" ¼	10 mt H07RNF	205	232	355	5,9
TS 800/S	180	94	60	350	1" ¼	10 mt H07RNF	205	232	396	8,4