

Diaphragm Valve, Metal

Construction

The GEMÜ 653 / 654 manually operated 2/2-way metal diaphragm valve has a stainless steel bonnet and is available in two versions - GEMÜ 653 has a handwheel in high temperature and chemically resistant plastic, GEMÜ 654 a stainless steel handwheel. The handwheel is non-rising (except diaphragm size 8) and has a standard optical position indicator. The valve is available with two bonnet versions: Design D has concealed bolt mounting in the bonnet and is only suitable for 2/2-way bodies. Design T is suitable for T valve, Multi-port valve, Tank bottom valve and 2/2-way valve bodies.

Features

- Suitable for inert, corrosive*, liquid and gaseous media
- CIP/SIP cleaning and sterilizing capabilities
- Autoclave capability
- Insensitive to particulate media
- Surface finishes down to 0.25 µm, electropolished
- Designed according to GMP (Good Manufacturing Practice)

Advantages

- The handwheel design allows minimal heat sink thus reducing the danger of burns injuries
- The service life of the diaphragm is increased to a maximum by the patented optional seal adjuster (US-patent 6,691,737 B2)
- Optional flow direction
- Installation for an optimized draining is possible
- Option
 - Lockable handwheel
 - Mounting for proximity switches for position feedback

*see information on working medium on page 2

Sectional drawing

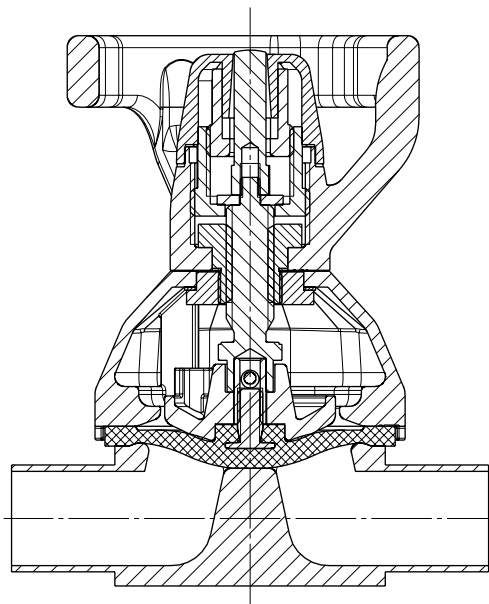

GEMÜ 653

Bonnet version "T"



Bonnet version "D"



GEMÜ 654

Bonnet version "T"



Bonnet version "D"

Technical data

Working medium

Corrosive, inert, gaseous and liquid media which have no negative impact on the physical and chemical properties of the body and diaphragm material.

The valve will seal in both flow directions up to full operating pressure (All pressures are gauge pressures).

Temperatures

Media temperature

FPM (Code 4/4A)	-10 ... 90 °C
EPDM (Code 13/3A)	-10 ... 100 °C
EPDM (Code 17)	-10 ... 100 °C
PTFE/EPDM (Code 54)	-10 ... 100 °C
PTFE/EPDM (Code 5M)	-10 ... 100 °C

Sterilisation temperature ⁽¹⁾

FPM (Code 4/4A)	not applicable
EPDM (Code 13/3A)	max. 150 °C ⁽²⁾ , max. 60 min per cycle
EPDM (Code 17)	max. 150 °C ⁽²⁾ , max. 180 min per cycle
PTFE/EPDM (Code 54)	max. 150 °C ⁽²⁾ , no time limit per cycle
PTFE/EPDM (Code 5M)	max. 150 °C ⁽²⁾ , no time limit per cycle

¹ The sterilisation temperature is valid for steam (saturated steam) or superheated water.

² If the sterilisation temperatures listed above are applied to the EPDM diaphragms for longer periods of time, the service life of the diaphragms will be reduced. In these cases, maintenance cycles must be adapted accordingly. This also applies to PTFE diaphragms exposed to high temperature fluctuations.

PTFE diaphragms can also be used as moisture barriers; however, this will reduce their service life.

The maintenance cycles must be adapted accordingly.

GEMÜ 555 and 505 globe valves are particularly suitable for use in the area of steam generation and distribution.

The following valve arrangement for interfaces between steam pipes and process pipes has proven itself over time:

A globe valve for shutting off steam pipes and a diaphragm valve as an interface to the process pipes.

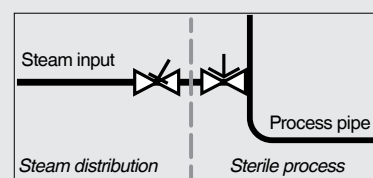

Ambient temperature

Standard	0 ... 60 °C
Accessory MAG	0 ... 35 °C

Temperature at mounting point for proximity switches see ambient temperature diagram below

Bonnet material

Bonnet	A4 stainless steel
Cap (DN 10 - DN 40)	PEEK
Cap (DN 50 - DN 100)	PES
653 handwheel	PPS glass filled
654 handwheel	A4 Edelstahl

Operating pressure [bar]

Diaphragm size	Nominal size	EPDM / FPM		PTFE		
		Diaphragm material	All valve body materials	Diaphragm material	Forged body*	Investment cast body
8	DN 4 - 15	3A, 4A, 17	0 - 10	54	0 - 10	0 - 6
10	DN 10 - 20	4, 13, 17	0 - 10	54	0 - 10	0 - 6
25	DN 15 - 25	4, 13, 17	0 - 10	5M	0 - 10	0 - 6
40	DN 32 - 40	4, 13, 17	0 - 10	5M	0 - 10	0 - 6
50	DN 50 - 65	4, 13, 17	0 - 10	5M	0 - 10	0 - 6
80	DN 65 - 80	4, 13, 17	0 - 10	5M	0 - 10	0 - 6
100	DN 100	4, 13, 17	0 - 10	54	0 - 10	0 - 6

All pressures are gauge pressures. Operating pressure values were determined with static operating pressure applied on one side of a closed valve. Sealing at the valve seat and atmospheric sealing is ensured for the given values. Information on operating pressures applied on both sides and for high purity media on request.

* With bonnet versions T and X. Bonnet version D: 0 - 6 bar

Technical data

Values measured at 25°C ambient temperature

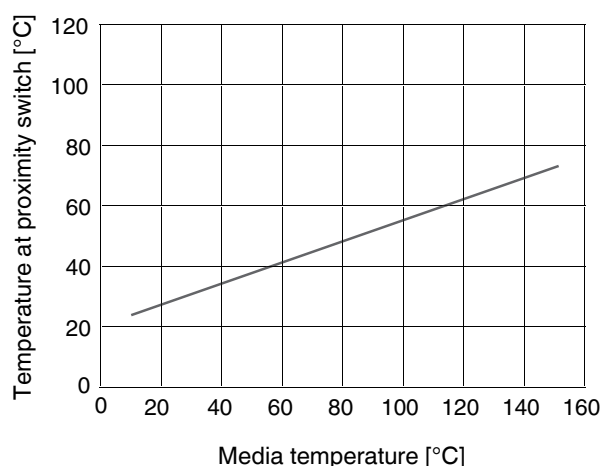

		Kv values [m ³ /h]						
Pipe standard		DIN	EN 10357 series B (formerly DIN 11850 series 1)	EN 10357 series A (formerly DIN 11850 series 2) / DIN 11866 series A	DIN 11850 Series 3	SMS 3008	ASME BPE / DIN 11866 series C	ISO 1127 / EN 10357 series C / DIN 11866 series B
Connection code		0	16	17	18	37	59	60
MG	DN							
8	4	0.5	-	-	-	-	-	-
	6	-	-	1.1	-	-	-	1.2
	8	-	-	1.3	-	-	0.6	2.2
	10	-	2.1	2.1	2.1	-	1.3	-
10	15	-	-	-	-	-	2.0	-
	10	-	2.4	2.4	2.4	-	2.2	3.3
	15	3.3	3.8	3.8	3.8	-	2.2	4.0
25	20	-	-	-	-	-	3.8	-
	15	4.1	4.7	4.7	4.7	-	-	7.4
	20	6.3	7.0	7.0	7.0	-	4.4	13.2
40	25	13.9	15.0	15.0	15.0	12.6	12.2	16.2
	32	25.3	27.0	27.0	27.0	26.2	-	30.0
50	40	29.3	30.9	30.9	30.9	30.2	29.5	32.8
	50	46.5	48.4	48.4	48.4	51.7	50.6	55.2
80	65	-	-	-	-	62.2	61.8	-
	65	-	-	77.0	-	68.5	68.5	96.0
100	80	-	-	111.0	-	80.0	87.0	111.0
	100	-	-	194.0	-	173.0	188.0	214.0

MG = diaphragm size

Kv values determined acc. to DIN EN 60534, inlet pressure 5 bar, Δp 1 bar, stainless steel valve body (forged body) and soft elastomer diaphragm. The Kv values for other product configurations (e.g. other diaphragm or body materials) may differ. In general, all diaphragms are subject to the influences of pressure, temperature, the process and their tightening torques. Therefore the Kv values may exceed the tolerance limits of the standard.

Order data

Body configuration	Code
Tank valve body	B**
2/2-way body	D
T body	T*
* For dimensions see T Valves brochure	
** Dimensions and versions on request	

Valve body material	Code
1.4435, investment casting	C3
1.4408, investment casting	37
1.4408, PFA lined	39
1.4435 (316L), forged body	40
1.4435 (BN2), forged body $\Delta Fe < 0.5\%$	42
1.4539, forged body	F4

Connection	Code
Butt weld spigots	
Spigots DIN	0
Spigots EN 10357 series B (formerly DIN 11850 series 1)	16
Spigot EN 10357 series A (formerly DIN 11850 series 2) / DIN 11866 series A	17
Spigots DIN 11850 series 3	18
Spigots JIS-G 3447	35
Spigots JIS-G 3459	36
Spigots SMS 3008	37
Spigots BS 4825 Part 1	55
Spigot ASME BPE / DIN 11866 series C	59
Spigot ISO 1127 / EN 10357 series C / DIN 11866 series B	60
Spigots ANSI/ASME B36.19M Schedule 10s	63
Spigots ANSI/ASME B36.19M Schedule 40s	65
Threaded connections	
Threaded sockets DIN ISO 228	1
Threaded spigots DIN 11851	6
One side threaded spigot, other side cone spigot and union nut, DIN 11851	62
Aseptic unions on request	
Flanges	
Flanges EN 1092 / PN16 / form B, length EN 558, series 1, ISO 5752, basic series 1	8
Flanges ANSI Class 150 RF, length MSS SP-88	38
Flanges ANSI Class 125/150 RF, length EN 558, series 1, ISO 5752, basic series 1	39
Clamp connections	
Clamps ASME BPE for pipe ASME BPE, length ASME BPE	80
Clamps DIN 32676 series B for pipe EN ISO 1127, length EN 558, series 7	82
Clamps ASME BPE for pipe ASME BPE, length EN 558, series 7	88
Clamps DIN 32676 series A for pipe DIN 11850, length EN 558, series 7	8A
Clamps SMS 3017 for pipe SMS 3008, length EN 558, series 7	8E
Aseptic clamps on request	
For overview of available valve bodies see page 16	

Diaphragm material	Code
FPM	4 4A*
EPDM	13 3A*
EPDM	17 17*
EPDM	36
PTFE/EPDM, one-piece	54*
PTFE/EPDM, two-piece	5M
* for diaphragm size 8	
Material complies with FDA requirements, except code 4 and 4A	

Control function	Code
Manually operated	0

Bonnet size	Code
Diaphragm size 8	0
Diaphragm size 10	1
Diaphragm size 25	2
Diaphragm size 40	3
Diaphragm size 50	4
Diaphragm size 80	5
Diaphragm size 100	6

Bonnet version	Code
For body configuration D (diaphragm size 10 - 50)	D
For body configurations B, D, M and T (diaphragm size 8 - 100)	T
Bonnet for special function for body configurations B, D, M and T (diaphragm size 10 - 100)	X

Order data

Bonnet function	Code
With seal adjuster and stroke limiter	(GEMÜ 653 diaphragm size 10 - 50) (GEMÜ 654 diaphragm size 8 - 100) H
Without seal adjuster and without stroke limiter	(GEMÜ 653 diaphragm size 10 - 100) (GEMÜ 654 diaphragm size 8 - 100) N
With seal adjuster	(diaphragm size 80 - 100) S
Special versions	
With seal adjuster, stroke limiter and mounting for proximity switches M 8x1	(diaphragm size 10 - 50) A*
With seal adjuster and mounting for proximity switches M 12x1	(diaphragm size 80 - 100)
With seal adjuster, stroke limiter, locking device (both directions) and mounting for proximity switches M 8x1	(diaphragm size 10 - 50) B*
With seal adjuster, locking device (both directions) and mounting for proximity switches M 12x1	(diaphragm size 80 - 100)
With seal adjuster, stroke limiter and safety gland packing	(diaphragm size 10 - 50) E*
With seal adjuster and safety gland packing	(diaphragm size 80 - 100)
With seal adjuster, stroke limiter, locking device to prevent closing and mounting for proximity switches M 8x1	(diaphragm size 10 - 50) F*
With seal adjuster, locking device to prevent closing and mounting for proximity switches M 12x1	(diaphragm size 80 - 100)
With seal adjuster, stroke limiter, locking device to prevent opening and mounting for proximity switches M 8x1	(diaphragm size 10 - 50) K*
With seal adjuster, locking device to prevent opening and mounting for proximity switches M 12x1	(diaphragm size 80 - 100)
* only in connection with bonnet version X	

Special function	Code
3-A compliant design	M

Order example	653	50	D	60	40	5M	0	4	D	H		1503	M
Type	653												
Nominal size		50											
Body configuration (code)			D										
Connection (code)				60									
Valve body material (code)					40								
Diaphragm material (code)						5M							
Control function (code)							0						
Bonnet size (code)								4					
Bonnet version (code)									D				
Bonnet function (code)										H			
Nominal size (mm)*													
Connection (code)*													
Surface finish (code see page 6)												1503	
Special function (code)													M

* only in T-valve version

Order data

Internal surface finishes for forged and block material bodies ¹

Readings for Process Contact Surfaces	Mechanically polished ²		Electropolished	
	Hygienic class DIN 11866	Code	Hygienic class DIN 11866	Code
Ra ≤ 0.80 µm	H3	1502	HE3	1503
Ra ≤ 0.60 µm	-	1507	-	1508
Ra ≤ 0.40 µm	H4	1536	HE4	1537
Ra ≤ 0.25 µm ³	H5	1527	HE5	1516

Readings for Process Contact Surfaces acc. to ASME BPE 2016 ⁴	Mechanically polished ²		Electropolished	
	ASME BPE Surface Designation	Code	ASME BPE Surface Designation	Code
Ra Max. = 0.76 µm (30 µinch)	SF3	SF3	-	-
Ra Max. = 0.64 µm (25 µinch)	SF2	SF2	SF6	SF6
Ra Max. = 0.51 µm (20 µinch)	SF1	SF1	SF5	SF5
Ra Max. = 0.38 µm (15 µinch)	-	-	SF4	SF4

Internal surface finishes for investment cast bodies

Readings for Process Contact Surfaces	Mechanically polished ²	
	Hygienic class DIN 11866	Code
Ra ≤ 6.30 µm	-	1500
Ra ≤ 0.80 µm	H3	1502
Ra ≤ 0.60 µm ⁵	-	1507

¹ Surface finishes of customized valve bodies may be limited in special cases.

² Or any other finishing method that meets the Ra value (acc. to ASME BPE).

³ The smallest possible Ra finish for pipe connections with an internal pipe diameter < 6 mm is 0.38 µm.

⁴ When using these surfaces, the bodies are marked according to the specifications of ASME BPE.

The surfaces are only available for valve bodies which are made of materials (e.g. GEMÜ material codes 40, 41, F4, 44) and use connections (e.g. GEMÜ connection codes 59, 80, 88) according to ASME BPE.

⁵ Not possible for GEMÜ connection code 59, DN 8 and GEMÜ connection code 0, DN 4.

Ra acc. to DIN EN ISO 4288 and ASME B46.1

Dimensions [mm]

Bonnet dimensions

MG	øB	A			A4			Weight [kg]
		H	N	S	H	N	S	
8	36	85	65	-	4.5	-	0.35	
10	63	86			2.0	-	0.65	
25	92	108			5.0	-	1.40	
40	114	145			9.0	-	2.20	
50	132	171			21.0	-	3.20	
80	211	231*	202	231	33.0*	18.0	33	
100	211	255*	223	255	43.0*	28.0	43	

*only GEMÜ 654

MG = diaphragm size

A4: projection of indicator spindle over highest point when bonnet is in the fully open position (approximate values)

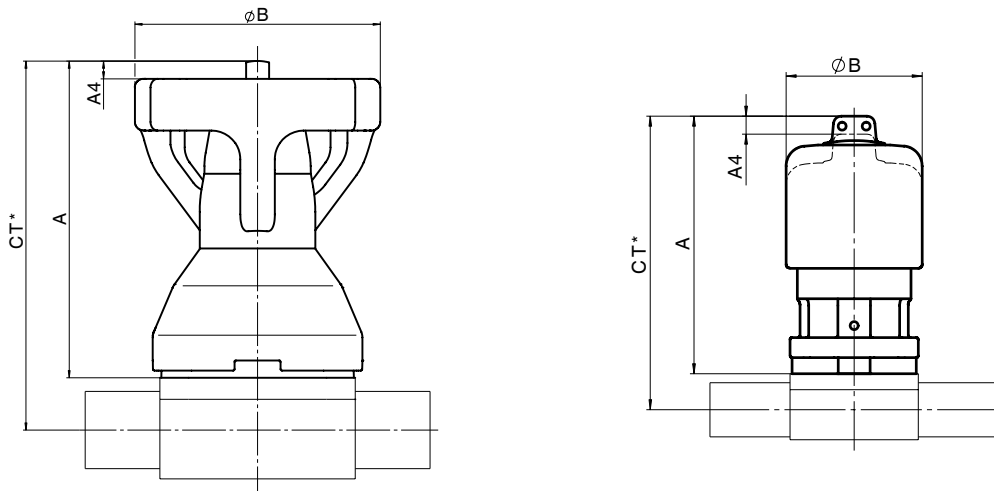

* CT = A + H1 (see body dimensions)

Dimensions: Special versions - Additional functions A, B, E, F, K,

MG	DN	øB	A	X MAG	X LOC	A4	Weight [kg]
10	10 - 20	63	124	107	73	2	0.7
25	15 - 25	92	159	112	78	5	1.7
40	32 - 40	114	192	119	85	9	2.8
50	50 - 65	132	233	125	91	21	4.3
80	65 - 80	211	290	142	108	33	10.5
100	100	211	323	152	118	43	12.5

X: only with additional functions B, F, K

MG = diaphragm size

A4: projection of indicator spindle over highest point when bonnet is in the fully open position (approximate values)

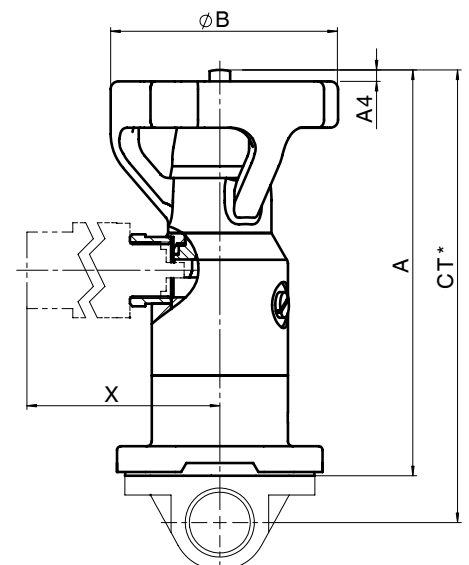

Body dimensions [mm]

Butt weld spigots, connection code 0, 16, 17, 18
Valve body material: Investment casting (code C3), forged body (code 40, F4)

Pipe standard							DIN		EN 10357 series B (formerly DIN 11850 series 1)		EN 10357 series A (formerly DIN 11850 series 2) / DIN 11866 series A		DIN 11850 Series 3		Weight [kg]
Connection code							0		16		17		18		
MG	DN	NPS	L	c	H1*	H1**	ød	s	ød	s	ød	s	ød	s	
8	4	-	72	20	8.5		6	1.0	-	-	-	-	-	-	0.09
	6	-	72	20	8.5		-	-	-	-	8	1.0	-	-	0.09
	8	1/4"	72	20	8.5		-	-	-	-	10	1.0	-	-	0.09
	10	3/8"	72	20	8.5		-	-	12	1.0	13	1.5	14	2.0	0.09
10	10	3/8"	108	25	12.5		-	-	12	1.0	13	1.5	14	2.0	0.30
	15	1/2"	108	25	12.5		18	1.5	18	1.0	19	1.5	20	2.0	0.30
25	15	1/2"	120	25	13.0	19.0	18	1.5	18	1.0	19	1.5	20	2.0	0.62
	20	3/4"	120	25	16.0	19.0	22	1.5	22	1.0	23	1.5	24	2.0	0.58
	25	1"	120	25	19.0	19.0	28	1.5	28	1.0	29	1.5	30	2.0	0.55
40	32	1 1/4"	153	25	24.0	26.0	34	1.5	34	1.0	35	1.5	36	2.0	1.45
	40	1 1/2"	153	25	26.0	26.0	40	1.5	40	1.0	41	1.5	42	2.0	1.32
50	50	2"	173	30	32.0	32.0	52	1.5	52	1.0	53	1.5	54	2.0	2.25
80	65	2 1/2"	216	30	-	62.0	-	-	-	-	70	2.0	-	-	8.60
	80	3"	254	30	-	62.0	-	-	-	-	85	2.0	-	-	8.00
100	100	4"	305	30	-	76.0	-	-	-	-	104	2.0	-	-	24.10

* only for investment cast design

** only for forged design

MG = diaphragm size

For materials see overview on page 16

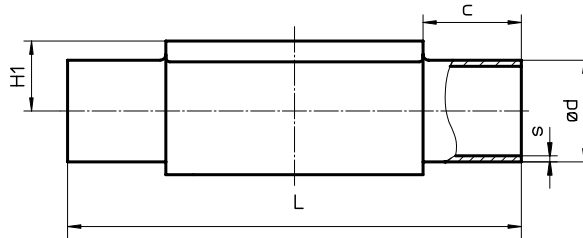

Body dimensions [mm]

Butt weld spigots, connection code 60
Valve body material: Investment casting (code C3), forged body (code 40, F4)

Pipe standard							ISO 1127 / EN 10357 series C / DIN 11866 series B		Weight [kg]
Connection code							60		
MG	DN	NPS	L	c	H1*	H1**	ød	s	
8	6	-	72	20	-	8.5	10.2	1.6	0.09
	8	1/4"	72	20	8.5	8.5	13.5	1.6	0.09
	10	3/8"	72	20	-	8.5	-	-	0.09
10	10	3/8"	108	25	12.5	12.5	17.2	1.6	0.30
	15	1/2"	108	25	12.5	12.5	21.3	1.6	0.30
25	15	1/2"	120	25	13.0	19.0	21.3	1.6	0.62
	20	3/4"	120	25	16.0	19.0	26.9	1.6	0.58
	25	1"	120	25	19.0	19.0	33.7	2.0	0.55
40	32	1 1/4"	153	25	24.0	26.0	42.4	2.0	1.45
	40	1 1/2"	153	25	26.0	26.0	48.3	2.0	1.32
50	50	2"	173	30	32.0	32.0	60.3	2.0	2.25
80	65	2 1/2"	216	30	-	62.0	76.1	2.0	8.60
	80	3"	254	30	-	62.0	88.9	2.3	8.00
100	100	4"	305	30	-	76.0	114.3	2.3	24.10

* only for investment cast design

** only for forged design

MG = diaphragm size

For materials see overview on page 16

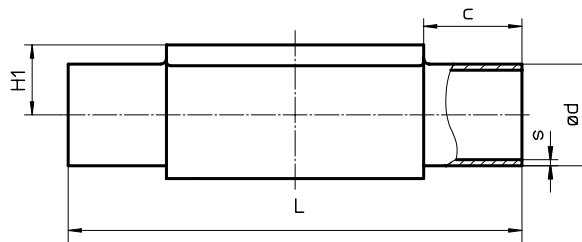

Body dimensions [mm]

Butt weld spigots, connection code 35, 36, 37
Valve body material: Investment casting (code C3), forged body (code 40, F4)

Pipe standard							JIS-G 3447	JIS-G 3459	SMS 3008		Weight [kg]		
Connection code							35	36	37				
MG	DN	NPS	L	c	H1*	H1**	ød	s	ød	s		ød	s
8	6	-	72	20	-	8.5	-	-	10.5	1.20	-	-	0.09
	8	1/4"	72	20	-	8.5	-	-	13.8	1.65	-	-	0.09
10	10	3/8"	108	25	-	12.5	-	-	17.3	1.65	-	-	0.30
	15	1/2"	108	25	-	12.5	-	-	21.7	2.10	-	-	0.30
25	15	1/2"	120	25	-	19.0	-	-	21.7	2.10	-	-	0.62
	20	3/4"	120	25	-	19.0	-	-	27.2	2.10	-	-	0.58
	25	1"	120	25	19.0	19.0	25.4	1.2	34.0	2.80	25.0	1.2	0.55
40	32	1 1/4"	153	25	-	26.0	31.8	1.2	42.7	2.80	33.7	1.2	1.45
	40	1 1/2"	153	25	26.0	26.0	38.1	1.2	48.6	2.80	38.0	1.2	1.32
50	50	2"	173	30	32.0	32.0	50.8	1.5	60.5	2.80	51.0	1.2	2.25
	65	2 1/2"	173	30	-	34.0	63.5	2.0	-	-	63.5	1.6	2.20
80	65	2 1/2"	216	30	-	62.0	63.5	2.0	76.3	3.00	63.5	1.6	8.60
	80	3"	254	30	-	62.0	76.3	2.0	89.1	3.00	76.1	1.6	8.00
100	100	4"	305	30	-	76.0	101.6	2.0	114.3	3.00	101.6	2.0	24.10

* only for investment cast design

** only for forged design

MG = diaphragm size

For materials see overview on page 16

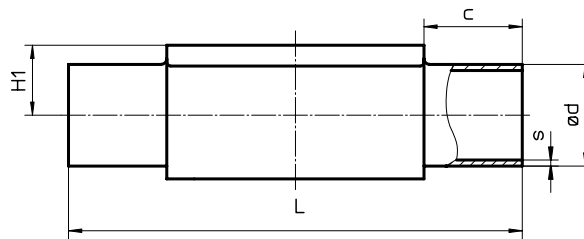

Body dimensions [mm]

Butt weld spigots, connection code 55, 59, 63, 65
Valve body material: Investment casting (code C3), forged body (code 40, F4)

Pipe standard							BS 4825 Part 1	ASME BPE / DIN 11866 series C	ANSI/ASME B36.19M Schedule 10s	ANSI/ASME B36.19M Schedule 40s	Weight [kg]				
Connection code							55	59	63	65					
MG	DN	NPS	L	c	H1*	H1**	ød	s	ød	s		ød	s	ød	s
8	6	-	72	20	-	8.5	-	-	-	-	10.3	1.24	10.3	1.73	0.09
	8	1/4"	72	20	8.5	8.5	6.35	1.2	6.35	0.89	13.7	1.65	13.7	2.24	0.09
	10	3/8"	72	20	8.5	8.5	9.53	1.2	9.53	0.89	-	-	-	-	0.09
	15	1/2"	72	20	8.5	8.5	12.70	1.2	12.70	1.65	-	-	-	-	0.09
10	10	3/8"	108	25	-	12.5	9.53	1.2	9.53	0.89	17.1	1.65	17.1	2.31	0.30
	15	1/2"	108	25	-	12.5	12.70	1.2	12.70	1.65	21.3	2.11	21.3	2.77	0.30
	20	3/4"	108	25	12.5	12.5	19.05	1.2	19.05	1.65	-	-	-	-	0.30
25	15	1/2"	120	25	-	19.0	-	-	-	-	21.3	2.11	21.3	2.77	0.62
	20	3/4"	120	25	16.0	19.0	19.05	1.2	19.05	1.65	26.7	2.11	26.7	2.87	0.58
	25	1"	120	25	19.0	19.0	-	-	25.40	1.65	33.4	2.77	33.4	3.38	0.55
40	32	1 1/4"	153	25	-	26.0	-	-	-	-	42.2	2.77	42.2	3.56	1.45
	40	1 1/2"	153	25	26.0	26.0	-	-	38.10	1.65	48.3	2.77	48.3	3.68	1.32
50	50	2"	173	30	32.0	32.0	-	-	50.80	1.65	60.3	2.77	60.3	3.91	2.25
	65	2 1/2"	173	30	-	34.0	-	-	63.50	1.65	-	-	-	-	2.10
80	65	2 1/2"	216	30	-	62.0	-	-	63.50	1.65	73.0	3.05	73.0	5.16	8.60
	80	3"	254	30	-	62.0	-	-	76.20	1.65	88.9	3.05	88.9	5.49	8.00
100	100	4"	305	30	-	76.0	-	-	101.60	2.11	114.3	3.05	114.3	6.02	24.10

* only for investment cast design

** only for forged design

MG = diaphragm size

For materials see overview on page 16

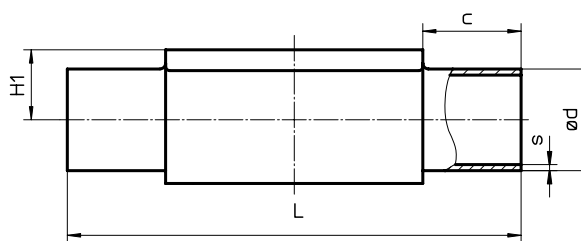

Body dimensions [mm]

Threaded sockets. connection code 1 Valve body material: investment casting (code 37)

MG	DN	R	H	H1	t	L	SW2	Number of flats	Weight [kg]
8	8	G 1/4	19	9	11	72	18	6	0.09
10	12	G 3/8	25	13	12	55	22	2	0.17
	15	G 1/2	30	15	15	68	27	2	0.26
25	15	G 1/2	29	16	15	85	27	6	0.32
	20	G 3/4	32	16	16	85	32	6	0.34
	25	G 1	37	16	13	110	41	6	0.39
40	32	G 1 1/4	49	24	20	120	50	8	0.88
	40	G 1 1/2	52	24	18	140	55	8	0.93
50	50	G 2	68	33	26	165	70	8	1.56

MG = Diaphragm size

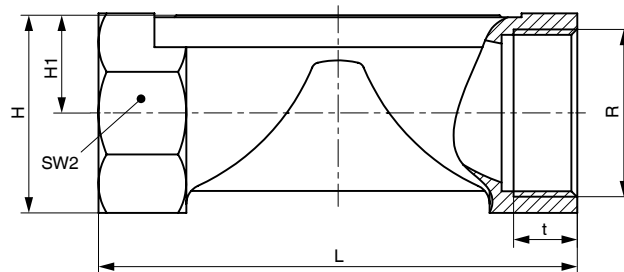

Body dimensions [mm]

Threaded connections, connection code 6, 62 Valve body material: Forged body (code 40)

MG	DN	H1	ød1	Thread to DIN 405 R	Code 6 L	Code 62 L	Weight [kg]
8	10	8.5	10.0	RD 28 x 1/8	92	90	0.21
10	10	12.5	10.0	RD 28 x 1/8	118	116	0.33
	15	12.5	16.0	RD 34 x 1/8	118	116	0.35
25	15	19.0	16.0	RD 34 x 1/8	118	116	0.71
	20	19.0	20.0	RD 44 x 1/6	118	114	0.78
	25	19.0	26.0	RD 52 x 1/6	128	127	0.79
40	32	26.0	32.0	RD 58 x 1/6	147	147	1.66
	40	26.0	38.0	RD 65 x 1/6	160	160	1.62
50	50	32.0	50.0	RD 78 x 1/6	191	191	2.70
80	65	62.0	66.0	RD 95 x 1/6	246	246	9.22
	80	62.0	81.0	RD 110 x 1/4	256	256	9.20

MG = diaphragm size

Code 6

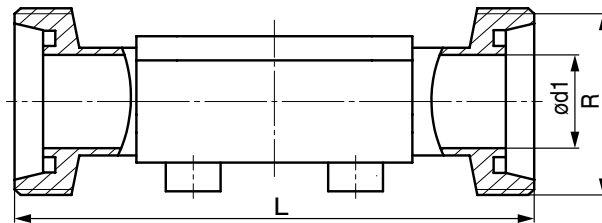

Code 62

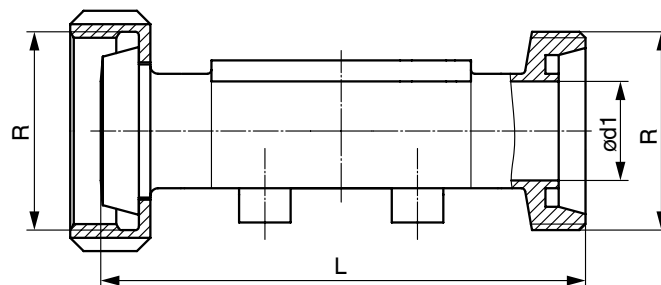

Body dimensions [mm]

Flanges - DIN EN 1092, connection code 8 Valve body material investment casting (code C3), forged body (code 40), investment casting PFA lined (code 39)

MG	DN	øD	øk	øL	Number of bolts	H1			FTF	Weight [kg]
						Material code C3	Material code 39	Material code 40		
25	15	95	65	14	4	13.0	18.0	19.0	130*	1.85
	20	105	75	14	4	16.0	20.5	19.0	150	2.35
	25	115	85	14	4	19.0	23.0	19.0	160	2.85
40	32	140	100	19	4	24.0	28.7	26.0	180	4.90
	40	150	110	19	4	26.0	33.0	26.0	200	5.65
50	50	165	125	19	4	32.0	39.0	32.0	230	7.45
80	65	185	145	19	4	-	51.0	62.0	290	10.20
	80	200	160	19	8	-	59.5	62.0	310	14.20
100	100	220	180	19	8	-	73.0	76.0	350	21.00

*Material code C3, 40 FTF = 150 (no DIN length)

MG = diaphragm size

For materials see overview on page 16

Flanges - ANSI Class 125/150 RF, connection code 38, 39 Valve body material investment casting (code C3), forged body (code 40), investment casting PFA lined (code 39)

MG	DN	øD	øk	øL	Number of bolts	H1			FTF		Weight [kg]
						Material code C3	Material code 39	Material code 40	Connection code 38	Connection code 39	
25	15	90	60.3	15.9	4	13.0	18.0	19.0	-	130	1.85
	20	100	69.9	15.9	4	16.0	20.5	19.0	146	150	2.35
	25	110	79.4	15.9	4	19.0	23.0	19.0	146	160	2.85
40	32	115	88.9	15.9	4	24.0	28.7	26.0	-	180	4.90
	40	125	98.4	15.9	4	26.0	33.0	26.0	175	200	5.65
50	50	150	120.7	19.0	4	32.0	39.0	32.0	200	230	7.45
80	65	180	139.7	19.0	4	-	51.0	62.0	226	290	10.20
	80	190	152.4	19.0	4	-	59.5	62.0	260	310	14.20
100	100	230	190.5	19.0	8	-	73.0	76.0	327	350	21.00

MG = diaphragm size

For materials see overview on page 16

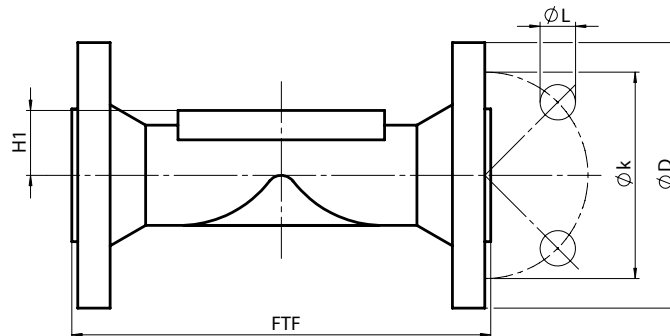

Body dimensions [mm]

Clamp connections, connection code 80, 82, 88, 8A, 8E Valve body material: Forged body (code 40, F4)

Pipe connection for clamp			ASME BPE							ISO 1127 / EN 10357 series C / DIN 11866 series B			EN 10357 series A (formerly DIN 11850 series 2) / DIN 11866 series A			SMS 3008			Weight [kg]
Clamp connection			ASME BPE							DIN 32676 series B			DIN 32676 series A			ISO 2852 / SMS 3017			
Clamp connection code			80			88			82			8A			8E				
MG	DN	NPS	H1	ød1	ød3	L	ød1	ød3	L	ød1	ød3	L	ød1	ød3	L	ød1	ød3	L	
8	6	1/8"	8.5	-	-	-	-	-	-	7.0	25.0	63.5	6	25.0	63.5	-	-	-	-
	8	1/4"	8.5	4.57	25.0	63.5	-	-	-	10.3	25.0	63.5	8	25.0	63.5	-	-	-	0.15
	10	3/8"	8.5	7.75	25.0	63.5	-	-	-	-	-	-	10	34.0	88.9	-	-	-	0.18
	15	1/2"	8.5	9.40	25.0	63.5	9.40	25.0	108	-	-	-	-	-	-	-	-	-	0.18
10	10	3/8"	12.5	-	-	-	-	-	-	14.0	25.0	108.0	10	34.0	108.0	-	-	-	0.30
	15	1/2"	12.5	9.40	25.0	88.9	9.40	25.0	108	18.1	50.5	108.0	16	34.0	108.0	-	-	-	0.43
	20	3/4"	12.5	15.75	25.0	101.6	15.75	25.0	117	-	-	-	-	-	-	-	-	-	0.43
25	15	1/2"	19.0	-	-	-	-	-	-	18.1	50.5	108.0	16	34.0	108.0	-	-	-	0.75
	20	3/4"	19.0	15.75	25.0	101.6	15.75	25.0	117	23.7	50.5	117.0	20	34.0	117.0	-	-	-	0.71
	25	1"	19.0	22.10	50.5	114.3	22.10	50.5	127	29.7	50.5	127.0	26	50.5	127.0	22.6	50.5	127	0.63
40	32	1 1/4"	26.0	-	-	-	-	-	-	38.4	64.0	146.0	32	50.5	146.0	31.3	50.5	146	1.62
	40	1 1/2"	26.0	34.80	50.5	139.7	34.80	50.5	159	44.3	64.0	159.0	38	50.5	159.0	35.6	50.5	159	1.50
50	50	2"	32.0	47.50	64.0	158.8	47.50	64.0	190	56.3	77.5	190.0	50	64.0	190.0	48.6	64.0	190	2.50
	65	2 1/2"	34.0	60.20	77.5	193.8	60.20	77.5	216	-	-	-	-	-	-	60.3	77.5	216	2.30
80	65	2 1/2"	62.0	60.20	77.5	193.8	60.20	77.5	216	72.1	91.0	216.0	66	91.0	216.0	60.3	77.5	216	8.90
	80	3"	62.0	72.90	91.0	222.3	72.90	91.0	254	84.3	106.0	254.0	81	106.0	254.0	72.9	91.0	254	8.50
100	100	4"	76.0	97.38	119.0	292.1	97.38	119.0	305	109.7	130.0	305.0	100	119.0	305.0	97.6	119.0	305	24.80

MG = diaphragm size

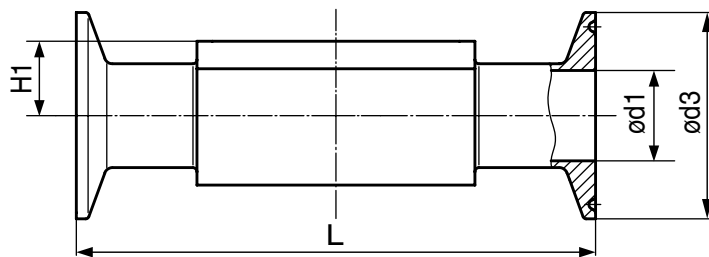

Overview of valve bodies for GEMÜ 653/654

		Spigots																
Connection code		0		16	17		18	35	36	37		55	59		60		63	65
Material code		C3	40	40	C3	40	40	40	40	C3	40	40	C3	40	C3	40	40	40
MG	DN																	
8	4	X	X	-	-	-	-	-	-	-	-	-	-	-	-	-	-	-
	6	-	-	-	X	X	-	-	X	-	-	-	-	-	-	X	X	X
	8	-	-	-	X	X	-	-	X	-	-	X	X	X	X	X	X	X
	10	-	-	X	X	X	X	-	-	-	-	X	X	X	-	-	-	-
	15	-	-	-	-	-	-	-	-	-	-	X	X	X	-	-	-	-
10	10	-	-	X	X	X	X	-	X	-	-	X	-	X	X	X	X	X
	15	-	X	X	X	X	X	-	X	-	-	X	-	X	X	X	X	X
	20	-	-	-	-	-	-	-	-	-	-	X	X	X	-	-	-	-
25	15	-	X	X	X	X	X	-	X	-	-	-	-	-	X	X	X	X
	20	-	X	X	X	X	X	-	X	-	-	X	X	X	X	X	X	X
	25	-	X	X	X	X	X	X	X	X	X	-	X	X	X	X	X	X
40	32	-	X	X	X	X	X	X	X	-	X	-	-	-	X	X	X	X
	40	-	X	X	X	X	X	X	X	X	X	-	X	X	X	X	X	X
50	50	-	X	X	X	X	X	X	X	X	X	-	X	X	X	X	X	X
	65	-	-	-	-	-	-	X	-	-	X	-	-	X	-	-	-	-
80	65	-	-	-	-	X	-	X	X	-	X	-	-	X	-	X	X	X
	80	-	-	-	-	X	-	X	X	-	X	-	-	X	-	X	X	X
100	100	-	-	-	-	X	-	X	X	-	X	-	-	X	-	X	X	X

Availability of material code 42, F4: same as code 40 MG = diaphragm size

		Threaded connections			Clamps					Flanges						
Connection code		1	6	62	80	82	88	8A	8E	8			38	39		
Material code		37	40	40	40	40	40	40	40	C3	39	40	39	C3	39	40
MG	DN															
8	6	-	-	-	-	K	-	K	-	-	-	-	-	-	-	-
	8	X	-	-	K	K	-	K	-	-	-	-	-	-	-	-
	10	-	W	W	K	-	-	W	-	-	-	-	-	-	-	-
	15	-	-	-	K	-	W	-	-	-	-	-	-	-	-	-
10	10	-	W	W	-	K	-	K	-	-	-	-	-	-	-	-
	12	X	-	-	-	-	-	-	-	-	-	-	-	-	-	-
	15	X	W	W	K	W	K	K	-	-	-	-	-	-	-	-
25	20	-	-	-	K	-	K	-	-	-	-	-	-	-	-	-
	15	X	W	W	-	W	-	K	-	W	X	W	-	W	X	W
	20	X	W	W	K	K	K	K	-	W	X	W	X	W	X	W
40	25	X	W	W	K	K	K	K	K	W	X	W	X	W	X	W
	32	X	W	W	-	W	-	K	K	W	X	W	-	W	X	W
50	40	X	W	W	K	W	K	K	K	W	X	W	X	W	X	W
	50	X	W	W	K	W	K	K	K	W	X	W	X	W	X	W
80	65	-	-	-	W	-	W	-	W	-	-	-	-	-	-	-
	65	-	W	W	K	K	K	K	K	-	-	W	-	-	-	W
100	80	-	W	W	K	W	K	W	K	-	X	W	X	-	X	W
	100	-	-	-	W	W	W	W	W	-	X	W	X	-	X	W

X = Standard, K = Connections completely machined (not welded), W = Welded construction
 Availability of material code 42, F4: same as code 40 MG = diaphragm size

Special versions

Additional function A
with seal adjuster, stroke limiter
and mounting for proximity switches M 8x1

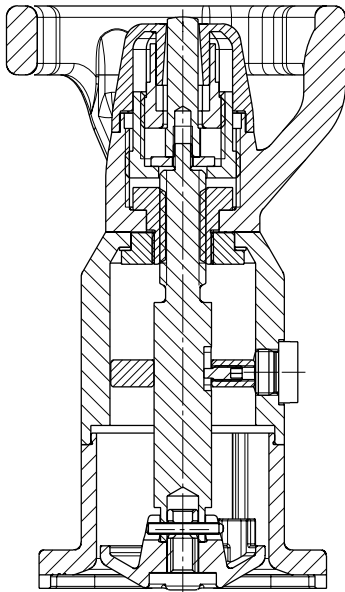

Additional function E
with seal adjuster, stroke limiter
and safety gland packing

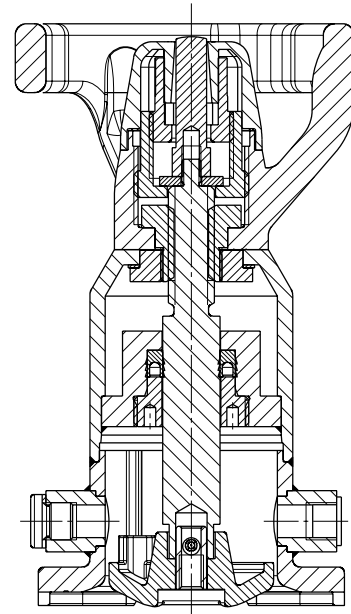

Additional function B, K, F

Types of locking devices

<p style="text-align: center;">B</p>	<p>B Mounting of locking device (both directions), proximity switch possible</p>
<p style="text-align: center;">K</p>	<p>K Mounting of locking device to prevent opening, proximity switch possible</p>
<p style="text-align: center;">F</p>	<p>F Mounting of locking device to prevent closing, proximity switch possible</p>

Type of accessory

MAG - Electrical locking device

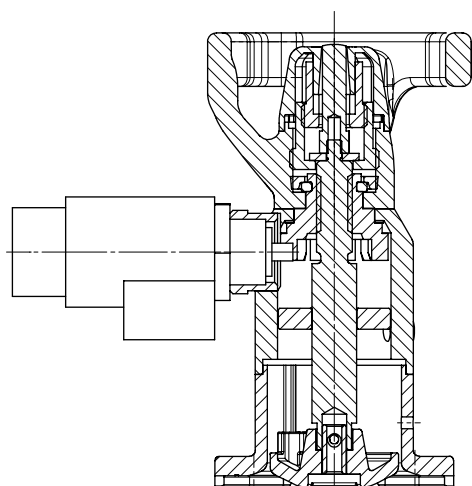

LOC - Mechanical locking device

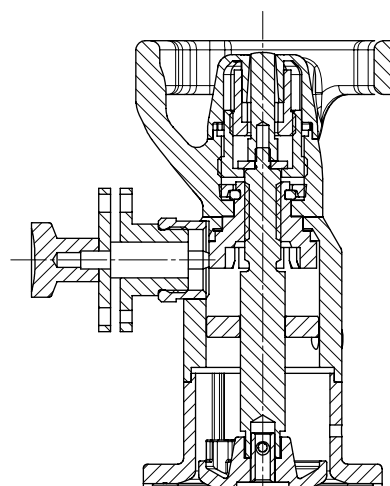

The solenoids, padlocks etc. for the "locking device" must be ordered separately as accessories.
Available only in connection with the bonnet additional functions B, K, F!

Order example	653	MAG	VE1	C1
Type	653			
Type of accessory		MAG		
Kit			VE1	
Voltage/Frequency (code)				C1

Type of accessory	MAG	- Electrical locking device
Kit	VE1	- Normally closed (locking device active)
Kit	VE2	- Normally open (locking device inactive)
Voltage/Frequency	C1	- 24 V DC

Type of accessory	LOC	- Mechanical locking device
Kit	VMB	- without padlock
Kit	VML	- with padlock

Special function		
ATEX	X	

EDP No.	Designation	Description
88264576	653MAGVE1 C1 X	Electromagnetic locking device 24 V DC, normally closed, M22x1 ATEX
88232776	653MAGVE1 C1	Electromagnetic locking device 24 V DC, normally closed, M22x1 IP 54, connector socket design A DIN EN 175301-803
88279388	653MAGVE2 C1	Electromagnetic locking device 24 V DC, normally open, M22x1 IP 54, connector socket design A DIN EN 175301-803
88239348	653LOCVML	Locking device M22x1 with padlock
88239405	653LOCVMB	Locking device M22x1 without padlock

GEMÜ 654 - 0TN (MG 8)



GEMÜ 654 - 0TH (MG 8)



GEMÜ 653 - T (MG 10 - 100)



GEMÜ 654 - T (MG 10 - 100)



GEMÜ 653 - D (MG 10 - 50)



GEMÜ 654 - D (MG 10 - 50)



GEMÜ 653 - LOC



GEMÜ 654 - MAG



GEMÜ 653 - proximity switches



For further metal diaphragm valves, accessories and other products, please see our Product Range catalogue and Price List. Contact GEMÜ.

GEMÜ VALVES, MEASUREMENT AND CONTROL SYSTEMS

